



HEIDENHAIN



Product Information

ROC 415

ROC 417

Absolute Singleturn
Rotary Encoders

December 2008

ROC 415/ROC 417 with Synchro Flange

- Rotary encoders for separate shaft coupling
- Shaft diameter 10 mm

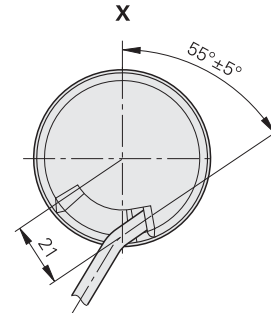
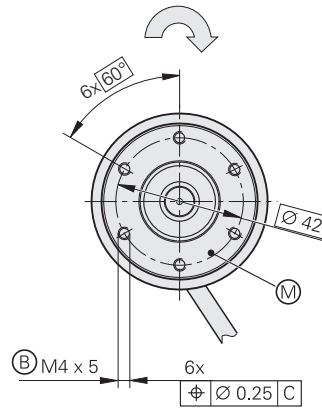
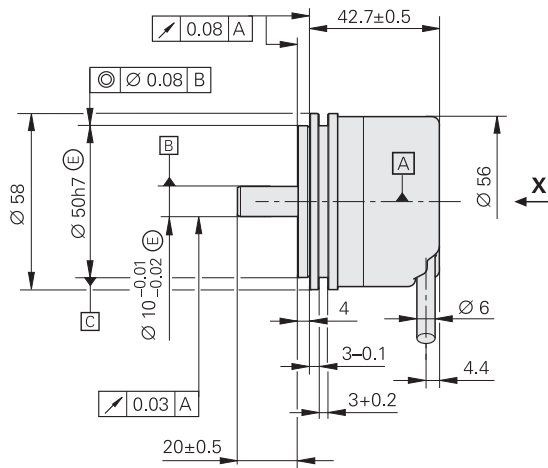

M23 flange socket

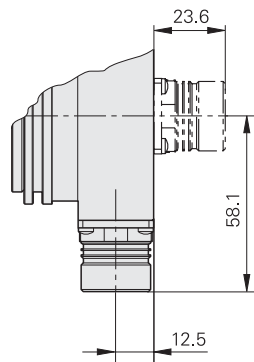

Dimensions in mm



Tolerancing ISO 8015
ISO 2768 - m H
< 6 mm: ±0.2 mm

Cable radial, also usable axially

▭ = Bearing

⊕ = Threaded mounting hole

Ⓜ = Measuring point for operating temperature

↻ = Direction of shaft rotation for output signals as per the interface description

	Absolute			
	Singleturn			
	ROC 415		ROC 417	
Absolute position values	SSI with additional parity bit	EnDat 2.2 Ordering designation EnDat 01	SSI with additional parity bit	EnDat 2.2 Ordering designation EnDat 01
Data word length	16 bits	15 bits	18 bits	17 bits
Positions per revolution	32 768 (15 bits)		131 072 (17 bits)	
Code	Pure binary			
Elec. permissible speed/ Deviations ¹⁾	≤ 1 500 min ⁻¹ /± 40 LSB ≤ 12 000 min ⁻¹ /± 270 LSB			
Calculation time t _{cal} Internal updating time	≤ 0.5 μs ≤ 5 μs	≤ 5 μs –	≤ 0.5 μs ≤ 5 μs	≤ 5 μs –
Incremental signals	~ 1 V _{PP} ²⁾			
Line counts	2048			
Cutoff frequency –3 dB	≥ 400 kHz			
System accuracy	± 10" (at 20 °C)			
Power supply Current consumption without load	5 V ± 5 % ≤ 160 mA	3.6 to 14 V ≤ 160 mA	5 V ± 5 % ≤ 160 mA	3.6 to 14 V ≤ 160 mA
Electrical connection*	<ul style="list-style-type: none"> • Flange socket M23, axial or radial • Cable 1 m/5 m, with or without coupling M23 			
Shaft	Solid shaft D = 10 mm			
Mech. permissible speed n	≤ 12 000 min ⁻¹			
Starting torque	≤ 0.025 Nm (at 20 °C) ≤ 0.2 Nm (at -40 °C)			
Moment of inertia of rotor	2.1 · 10 ⁻⁶ kgm ²			
Shaft load ³⁾	Axial 10 N/radial 20 N at shaft end			
Vibration 55 to 2 000 Hz Shock 6 ms/2 ms	≤ 300 m/s ² (EN 60068-2-6) ≤ 1 000 m/s ² /≤ 2 000 m/s ² (EN 60068-2-27)			
Max. operating temperature	80 °C			
Min. operating temperature	Flange socket or fixed cable: –40 °C Moving cable: –10 °C			
Relative air humidity	≤ 75 %; temporary ≤ 96 % (condensation not permissible)			
Protection EN 60529	IP 67 at housing; IP 66 at shaft inlet			
Weight	Approx. 0.55 kg			

Bold: This preferred version is available on short notice

* Please indicate when ordering

¹⁾ Speed-dependent deviations between absolute value and incremental signal

²⁾ Limited tolerances: Signal size 0.8 to 1.2 V_{PP}

³⁾ See also *Mechanical Design Types and Mounting* in the *Rotary Encoders* catalog

Shaft Couplings

The shaft coupling compensates axial movement and misalignment between the encoder shaft and the measured shaft, preventing excessive load on the encoder bearing of the angle encoder.

	Diaphragm couplings with galvanic isolation			Flat coupling
	K 03	K 17/02 K 17/04	K 17/03	K18
Hub bore	10 mm	6/10 mm 10 mm	10 mm	10 mm
Kinematic transfer error*	± 2"	± 10"		± 3"
Torsional rigidity	1 500 Nm/rad	200 Nm/rad	300 Nm/rad	1 200 Nm/rad
Torque	0.2 Nm	0.1 Nm	0.2 Nm	0.5 Nm
Radial offset λ	≤ 0.3 mm	≤ 0.5 mm		≤ 0.3 mm
Angular error α	≤ 0.5°	≤ 1°		≤ 0.5°
Axial motion δ	≤ 0.2 mm	≤ 0.5 mm		≤ 0.2 mm
Moment of inertia (approx.)	$20 \cdot 10^{-6} \text{ kgm}^2$	$3 \cdot 10^{-6} \text{ kgm}^2$	$4 \cdot 10^{-6} \text{ kgm}^2$	$75 \cdot 10^{-6} \text{ kgm}^2$
Permissible speed	10000 min^{-1}	16000 min^{-1}		1000 min^{-1}
Torque for locking screws (approx.)	1.2 Nm			
Weight	100 g	23 g	275 g	117 g

*With radial misalignment $\lambda = 0.1 \text{ mm}$, angular error $\alpha = 0.15 \text{ mm}$ over $100 \text{ mm} \hat{=} 0.09^\circ$ valid up to 50°C

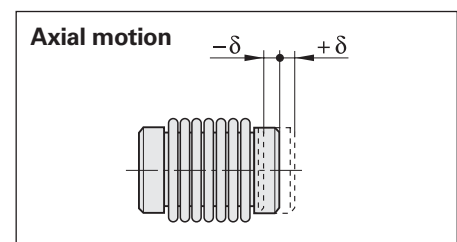
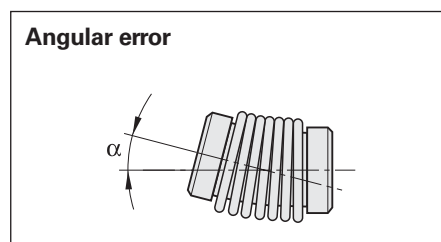
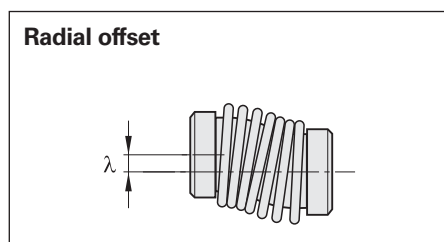

Mounting Accessories

Screwdriver bit Screwdriver

See *Rotary Encoders Catalog*

Diaphragm coupling K 03

ID 200313-04

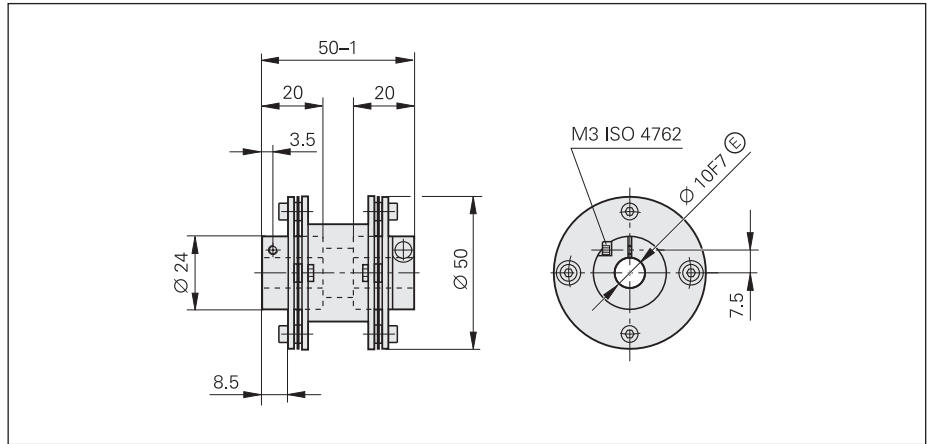

Diaphragm coupling K 17

with galvanic isolation
for ROC/ROQ/ROD 400 series
with **6 or 10 mm shaft diameter**
ID 296 746-xx

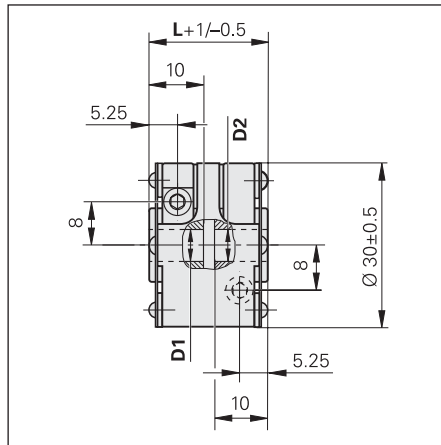

K 17 variants	D1	D2	L
02	Ø 6 F7	Ø 10 F7	22 mm
03	Ø 10 F7	Ø 10 F7	30 mm
04	Ø 10 F7	Ø 10 F7	22 mm

Flat coupling K 18

ID 202227-01

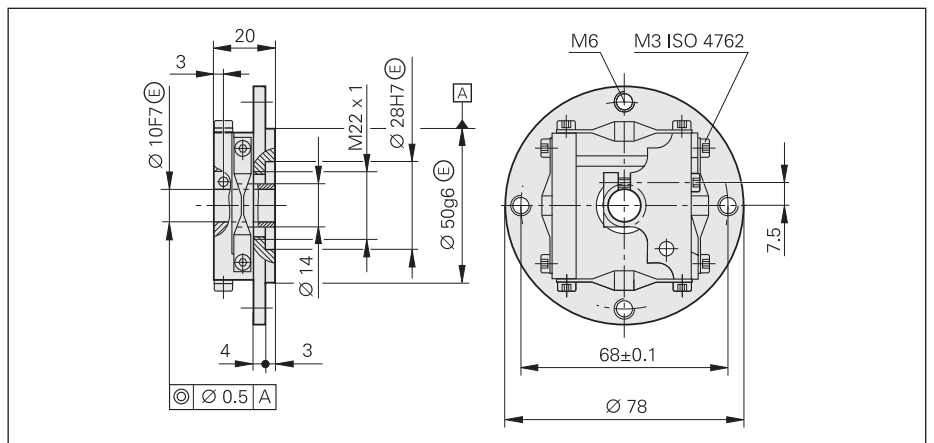

Dimensions in mm



Tolerancing ISO 8015
ISO 2768 - m H
< 6 mm: ±0.2 mm

Interfaces

SSI Absolute Position Values

The **absolute position value** beginning with the Most Significant Bit (MSB first) is transferred on the DATA lines in synchronism with a CLOCK signal transmitted by the control. The position value is followed by a parity bit. The data word length therefore deviates from the SSI standard. On the ROC 415 it is 16 bits and on the ROC 417, 18 bits. In addition to the absolute position values, sinusoidal **incremental signals** with $1 \cdot V_{PP}$ levels are transmitted. For signal description see *Incremental signals 1 V_{PP}*.

Interface	SSI serial
Data transfer	Absolute position values
Data input	Differential line receiver according to EIA standard RS 485 for the CLOCK and $\overline{\text{CLOCK}}$ signals
Data output	Differential line driver according to EIA standard RS 485 for the signals DATA and $\overline{\text{DATA}}$
Code	Pure binary code
Ascending position values	With clockwise rotation (viewed from flange side)
Incremental signals	$\sim 1 V_{PP}$ (see <i>Incremental signals 1 V_{PP}</i>)
Connecting cable	HEIDENHAIN cable with shielding PUR [(4 x 0.14 mm ²) + 4(2 x 0.14 mm ²) + (4 x 0.5 mm ²)]
Cable length	Max. 150 m at 90 pF/m distributed capacitance
Propagation time	6 ns/m

Control cycle for complete data format

When not transmitting, the clock and data lines are on high level. The current position value is stored on the first falling edge of the clock. The stored data is then clocked out on the first rising edge.

After transmission of a complete data word, the data line remains low for a period of time (t_2) until the encoder is ready for interrogation of a new value. If another data-output request (CLOCK) is received within this time, the same data will be output once again.

If the data output is interrupted (CLOCK = high for $t \geq t_2$), a new position value will be stored on the next falling edge of the clock, and on the subsequent rising edge it will be clocked out to the subsequent electronics.

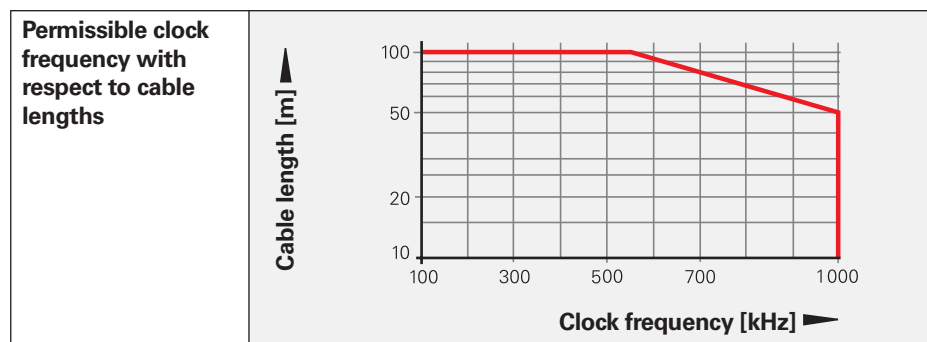
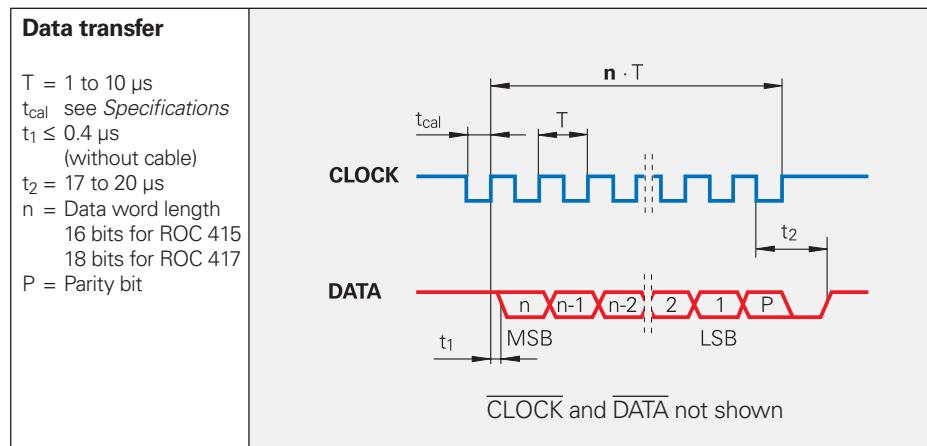

Input circuitry of the subsequent electronics

Dimensioning

IC₁ = Differential line receiver and driver

E.g. SN 65 LBC 176
LT 485

$Z_0 = 120 \Omega$



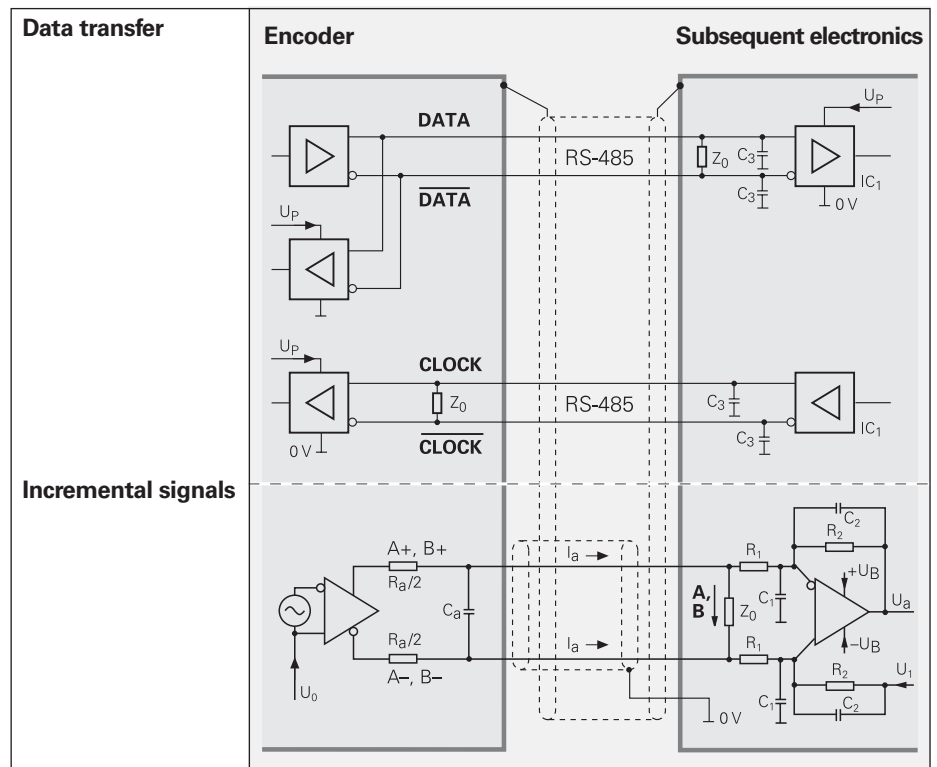

$C_3 = 330 \text{ pF}$ (serves to improve noise immunity)

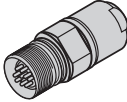

For an interface description of 1 V_{PP} and EnDat see *Rotary Encoders* catalog.

Electrical Connection

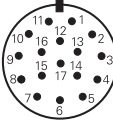
Pin layout





17-pin coupling M23   													
	Power supply					Incremental signals				Absolute position values			
	7	1	10	4	11	15	16	12	13	14	17	8	9
	U_P	Sensor U _P	0V	Sensor 0V	Internal shield	A+	A-	B+	B-	DATA	DATA	CLOCK	CLOCK
	Brown/ Green	Blue	White/ Green	White	/	Green/ Black	Yellow/ Black	Blue/ Black	Red/ Black	Grey	Pink	Violet	Yellow



Shield is on housing; **U_P** = power supply

Sensor: The sensor line is connected internally to the respective power supply.

Vacant pins or wires must not be used.

Connecting cable, 17-pin M23

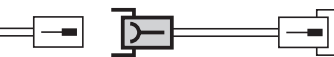
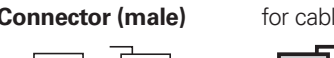
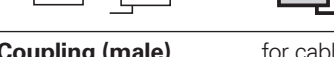
Connecting cable PUR [(4 × 0.14 mm ²) + 4(2 × 0.14 mm ²) + (4 × 0.5 mm ²)]		
Complete with connector (female) and coupling (male)		323897-xx
Complete with connector (female) and D-sub connector (female) for IK 220		332 115-xx
Complete with connector (female) and D-sub connector (male) for IK 115/IK 215		324544-xx
With one connector (female)		309778-xx
Cable without connectors , Ø 8 mm		266306-01

Mating element on connecting cable to connector on encoder cable	Connector (female) for cable Ø 8 mm 	291697-26
Connector on cable for connection to subsequent electronics	Connector (male) for cable Ø 8 mm 	291697-27
Coupling on connecting cable	Coupling (male) for cable Ø 6 mm Ø 8 mm 	291698-26 291698-27
Flange socket for mounting on the subsequent electronics	Flange socket (female) 	315892-10

HEIDENHAIN

DR. JOHANNES HEIDENHAIN GmbH
 Dr.-Johannes-Heidenhain-Straße 5
 83301 Traunreut, Germany
 ☎ +49 (8669) 31-0
 📠 +49 (8669) 5061
 E-mail: info@heidenhain.de

www.heidenhain.de

For more information

- Catalog: *Rotary Encoders*